

CONTENTS

Safety precautions	12-16
Description	17
New machine	17
Attaching Rotavator to the tractor	18
Depth control	18
Rotors	18
Lubrication + maintenance	19
Operating instructions	19
Operational advice	20

Introduction

Howard would like to thank you for purchasing this Rotavator and offer their support and assistance throughout its productive life.

This Rotavator has been designed and manufactured as a tractor driven, ground cultivator - no other use is intended.

Please read and understand this manual before operating the Rotavator.

Warranty

The warranty applicable to your machine is detailed on separate documentation which should accompany this manual. If this is missing, please contact your dealer.

Serial Number

The Serial Number and Model are stamped on the Identification Plate attached to your Rotavator. For future reference record this information below. Always quote them when ordering spare parts.

MODEL _____

SERIAL No. _____

Date Purchased: _____

SAFETY PRECAUTIONS



PLEASE READ. IT MAY SAVE A LIFE. SAFETY IS YOUR RESPONSIBILITY.

The safety of operators and any other connected personnel is a major component of; machine design, manufacture, retailing, commissioning, operation and maintenance. Howard have designed and manufactured this Rotavator with as many safety features as possible. The retailer's responsibility is to ensure you have selected the correct Rotavator for your tractor/application and to commission this machine.

Your responsibilities as owner or operator are to ensure the safety of any personnel in connection with; the operation, transport, maintenance or storage of this Rotavator. Be aware of your responsibilities and carry them out. The owner or an appropriately designated officer, if the owner is a company or corporation, is responsible for all safety issues related to this Rotavator.

The most important safety device attached to this Rotavator is a Safety Conscious Operator whose training and experience must include:

- Correct and complete installation and commissioning of the machine to ensure safe and reliable operation in the intended application.
- Training in safety issues, operation and maintenance of this machine in its application prior to beginning work. This training is to be reviewed or repeated annually.
- Being aware of their environment to the extent that unforeseen safety issues that may arise are dealt with to ensure the safety of all personnel (including operators, maintenance personnel and bystanders).

This is the SAFETY ALERT symbol and means:



ATTENTION ! SAFETY ISSUE !

Failure to comply with the given instruction could result in severe injury or death.

If you have questions not answered in this manual please contact your dealer or distributor.

IF YOU REQUIRE MORE COPIES OF THIS MANUAL PLEASE CONTACT YOUR DEALER. ALTERNATIVELY YOU ARE WELCOME TO COPY AND DISTRIBUTE THIS MANUAL TO THE OPERATORS AND MAINTENANCE PERSONNEL.

SAFETY DECAL CARE

- Keep safety decals clean and legible at all times. Replace any missing safety decals or any that have become illegible. Safety decals can be purchased from you dealer or distributor.
- If any part is replaced that supports a safety decal ensure that a decal is affixed to the replacement part.

ATTACHING SAFETY DECALS

1. Clean and dry the area where the decal is to be affixed. Warm soapy water is the best as some cleaning agents leave an oily film which may prevent the decal adhering.
2. Remove/fold back a small portion of the backing and affix the exposed portion of the decal in the desired position.
3. Peel back the remaining backing paper from under the decal and smooth down the decal with a rag, working any bubbles towards the edge of the decal.
4. Any bubbles that remain trapped can be pierced with a pin and smoothed down.

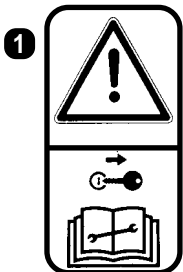

WARNING! READ CAREFULLY THE INSTRUCTIONS. BEFORE HANDLING OR REPAIRING THE MACHINE REMOVE THE TRACTOR IGNITION KEY

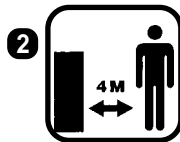

STAY AT LEAST AT A DISTANCE OF 4 METERS WHEN THE ROTAVATOR IS RUNNING.

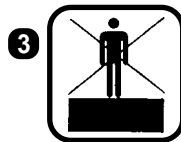

DO NOT STAY ON THE ROTAVATOR WHEN TRANSPORTING NEITHER WORKING



LIFTING POINT



THE DRIVE IS BY A PTO FROM A 540 TPM TRACTOR PTO



DANGER! OBJECTS PROJECTION.



MAINTAIN HANDS AND FEET AWAY WHEN ROTAVATOR IS WORKING

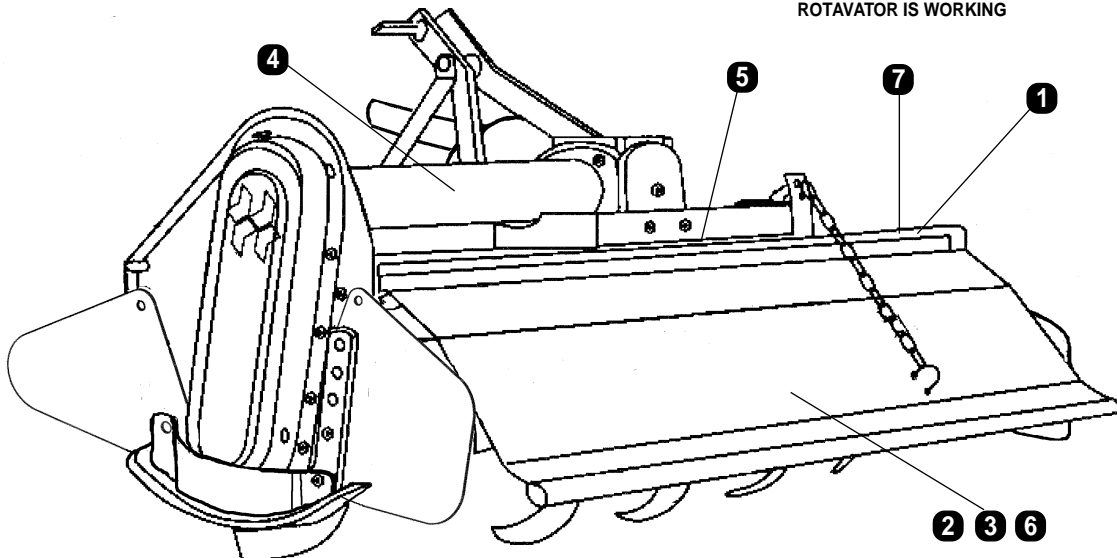

AT ALL TIMES

- Use the Rotavator only for the purpose for which it has been designed, and in accordance with the instructions in this operators manual.
- Ensure that only responsible, properly instructed people operate this machinery. Inexperienced operators will require training, followed initially by careful supervision.
- Children are not permitted to operate this machinery.
- Keep children well clear and appropriately supervised when connecting/disconnecting the tractor, operating or maintaining this machinery.
- Do not wear clothes that are loose fitting or with drawstring ties which can catch in moving parts.
- Wear appropriate protective clothing and equipment. Boots are a minimum, however if your tractor is not fitted with a controlled environment cab you may also need protection from prolonged exposure either to noise, dust or sunlight.
- Interpret 'Left' and 'Right' as if seated in the operators seat and facing forward.

BEFORE OPERATION

- Read and understand this manual.
- The tractor to be connected to the Rotavator:
 - Must be the tractor that the Rotavator has been commissioned to operate with. Check that it has been correctly maintained and has not been re-configured (for example front weights removed etc) which may reduce stability and control.
 - Consult the Tractor Manufacturers Manual for instructions on mounting implements and safe working methods.
 - Is recommended to be fitted with a Roll Over Protection System (ROPS).
 - Must be one the operator is familiar with.
- Prior to starting the tractor ensure the PTO is disengaged and the tractor is in neutral.
- Do not allow anyone to stand between the tractor and Rotavator while backing the tractor up to attach it.
 - Quick hitch systems are recommended for both Safety and convenience.
 - Before attempting to connect the universal drive shaft to the tractor, lower the Rotavator to the ground, stop the tractor, apply the park brake and remove the key.
- Visually inspect the Rotavator and check:
 - Hitch pins and drive shaft are secure.
 - No components are excessively worn, cracked or otherwise defective and all bolts are tight.
 - Guards, covers, warning labels and safety devices are all correctly fitted and operative.
 - Maintenance as per schedule has been carried out.
 - No tools or other unsecured items have been left on the Rotavator.
- Practice operation of the tractor and Rotavator combination.
 - Take sufficient time to become completely familiar with all controls, particularly those required to bring both tractor and Rotavator to an emergency stop if so required.
 - Progress slowly initially and check stability, steering and braking are satisfactory.

- Ensure the work area is clear, especially of children or animals.
- Inspect the work area for hidden obstructions which may constitute a hazard.

DURING OPERATION

- Ensure the work area is clear, especially of children or animals.
- Do not attempt to start the tractor or engage the PTO until correctly seated in the driver's seat.
- Never leave the tractor running unattended.
- Do not allow passengers on the Rotavator. [Or on the tractor unless approved seating is available.]
- Never attempt to make adjustments or perform maintenance functions while the Rotavator is operating.
- Observe all safe driving procedures:
 - Reduce speed when working on sloping ground or during sharp turns.
 - Do not attempt to work on steeply sloping ground where there is a risk of the tractor overturning.
 - Do not attempt to work near the edge of drop-offs or banks.
 - Avoid sudden starts and stops.
- After striking an obstacle, stop the tractor and implement and inspect it for damage. Repair as necessary before continuing.
- Disengage the PTO when transporting the implement or when not in use.
- When halting operation, even temporarily, lower the Rotavator to the ground, stop the tractor, apply the park brake and remove the key.
- Allow the Rotavator sufficient time to cool down before performing any maintenance, or changing gears in the Selectaspeed gearbox. [Oil and other transmission components may be hot enough to inflict burns.]
- Note:
 - By virtue of its mode of operation it is not possible to totally enclose a Rotavator with guards.
 - Contact with the blades while operating can result in severe injury or death.
 - Do not allow anybody (operators, maintenance personnel, bystanders or especially children) anywhere near the blades whilst the implement is operating. Note that children will often be attracted to placing objects into the blades if you leave it running - this machine is not a toy.
 - Be aware that Rotavator blades will not only cut, but drag limbs etc. into further danger.
 - Ensure that all shielding is in place before operating. If guards are removed for maintenance work, ensure they are replaced correctly upon completion. Repair or replace any damaged guards.
 - NEVER place hands or feet under the Rotavator, nor endeavour to make any repairs or adjustments while the blades are rotating; they are capable of inflicting serious injury.
 - NEVER touch the blades or attempt to free any jammed obstacle while the tractor engine is running. The clutch may be slipping and removal of any obstruction may allow the blades to rotate, the result possibly being serious injury.

FOLLOWING OPERATION

- Visually inspect the Rotavator and check:
 - All bolts are tight.
 - That no components are excessively worn, cracked, damaged or otherwise defective.
- Note and organise any maintenance required.
- Allow the Rotavator sufficient time to cool down before performing any maintenance. The gearboxes, lubricant and other transmission components may be hot enough to inflict burns.
- Refer to TRANSPORT SAFETY and STORAGE SAFETY for issues related to travel to/from operation and disconnection of the Rotavator from the tractor.

STORAGE SAFETY

- When unhitching the Rotavator and before leaving the tractor to disconnect the universal drive shaft and remove hitch pins:
 - Check that the PTO drive has been disengaged.
 - Stop the tractor, apply the park brake and remove the key.
- Store the Rotavator away from human activity and in particular do not permit children to play around, or on, stored equipment.
- Store the Rotavator in a dry level area and ensure parkstands and wheels/roller are securely positioned to prevent it tipping, falling over or rolling onto any personnel (particularly children).

MAINTENANCE SAFETY

- Maintain the Rotavator as detailed in the given schedule and check for any damage after use. Poor maintenance is an invitation to trouble.
- Ensure that all shielding is correctly in place when maintenance is completed. Repair or replace any damaged guards. Warning or instruction decals are to be kept in a readable condition; unreadable decals must be replaced.
- NEVER place hands or feet under the Rotavator nor endeavour to make any repairs or adjustments, while the blades are rotating; they are capable of inflicting serious injury.
- If working on the implement whilst it is raised on the tractor's three-point linkage, ensure:
 - That the tractor is turned off and the ignition key is removed to prevent accidental starting.
 - The park brake is engaged and the wheels chocked to prevent the tractor moving.
 - The PTO drive is disengaged.
 - The Rotavator is properly supported by blocks or stands. DO NOT rely on the tractor's hydraulic system to support the implement.
- Modifications or fitment of non genuine replacement parts.
 - If the equipment is modified in any way from the original design, the manufacturer will not accept any liability for any injury or warranty as a result of their use or attempted fitment.
- Fasteners.
 - Fit only the correct replacement fasteners and tighten fasteners to the torque specified in the manual. Incorrect (too weak) fasteners may break when torqued

to the required setting or, if too strong, may induce failures in other components.

- Follow safe workshop practices during any maintenance:
 - Keep working area clean, dry and in particular free of oil spills.
 - Ensure the workshop is adequately ventilated. Do not run the tractor engine inside a closed building. The exhaust fumes can reduce mental alertness initially and will progressively cause death by asphyxiation.
 - Use tools, lifting or jacking equipment suitably capable of the intended task.
 - Ensure electrical equipment is safe to use before operating.
 - A fire extinguisher and first aid kit should be readily accessible during maintenance.
 - Tools, parts and other service equipment must be removed to appropriate storage locations prior to any test running.
 - Do not wear baggy, ill-fitting or frayed clothing when working around transmission components.
 - Wear suitable gloves when handling or working with sharpened cutting elements.
 - Ensure bystanders, especially small children, are kept clear during maintenance or while making any adjustments.
- Hydraulic fluid can be dangerous.
 - When disconnecting any hydraulic fluid line, shut off the hydraulic supply and relieve the hydraulic pressure.
 - Never use hands to locate hydraulic fluid leaks. Escaping hydraulic fluid is capable of cutting and penetrating skin. Use a small piece of cardboard or wood.
 - Minor cuts are susceptible to infection from hydraulic fluid. Gangrene can result. If injured by escaping hydraulic fluid or you suspect you have been infected, seek medical treatment immediately.

TRANSPORT SAFETY

- When transporting the implement on a tractor on public roads ensure that you comply with the relevant regulations.
 - Class of roads permitted for travel may be restricted.
 - Transport may be restricted to daylight or, off peak traffic hours.
 - Signs indicating width may be required.
 - Lights indicating vehicle width if transported within the hours of darkness may be required.

If in doubt, contact your government department responsible for road transport.

- Secure the Rotavator for transport.
 - Disengage the PTO when transporting.
 - Ensure all hitch pins are correctly fitted with retaining pins.
 - Mechanically secure hydraulic cylinders to prevent cylinders creeping.
- Observe the tractor manufacturer's regulations and recommendations - specifically those relating to:
 - Maximum transport loads.
 - Maximum speed.
- Passengers

- Do not allow passengers to ride on the tractor unless a specific seat is provided.
- Do not allow anyone to ride on the implement when it is being transported.
- Consider other road users.
 - Plan your route to avoid heavy traffic and peak traffic periods.
 - Be a safe and courteous driver. Give way to oncoming traffic in all situations, including narrow bridges, intersections etc.
- Adopt safe driving practices:
 - Lock tractor brake pedals together. Never use independent breaking at transport speeds.
 - Drive at a safe speed to ensure control and ability to stop in an emergency. Ensure the additional weight of the Rotavator on the linkage does not compromise steering and braking - for example front weights or repairs to the brakes may be required if the tractor is not safe to drive.
 - Reduce speed during turns. Tractors have not been designed for fast cornering.
 - Use engine braking when going down hills - do not coast.
 - Do not drink alcohol and drive.
- Watch for obstructions, particularly if over-width.
- Observe any load ratings applicable on bridges.

IDENTIFICATION OF HAZARDS

- Owners and operators must be prepared to assess their; equipment, operators, maintenance procedures and applications to identify safety hazards.
- Appropriate methods to reduce the hazards identified must then be applied.

MACHINE SUITABILITY TO APPLICATION

Rotavators have been designed and manufactured as a tractor driven, ground cultivator - no other use is intended. However over the years some models have been adapted for new uses, such as road-base preparation and semi-industrial mixing operations.

- Before beginning work it is necessary to assess the effect of the machine on the safety of both the operator and any potential bystanders. It is recommended that you contact the manufacturer or distributor for assistance in this area.

AUTHORISED OPERATORS & TRAINING

If you are an employer, do not assume an operator is trained for use of this equipment, (you would not let an unlicensed driver borrow your car !).

- Ask to see licences if applicable, and record numbers and validity dates.
- Request details of previous experience, in writing and check them out if appropriate and ensure such records are retained.
- Devise a suitable training course for operators if appropriate, and ensure records of their completion are retained.

MAINTENANCE RECORDS

Recommended maintenance is detailed in the Lubrication & Maintenance section. Failure to follow these may jeopardise safety as well as economic operation.

Records of periodic maintenance are important as they detail when and who carried out the last maintenance and inspection. Appropriate checklists should include maintenance as detailed and in particular the following safety aspects:

- SAFETY DECALS AFFIXED & LEGIBLE.
- GUARDING - All fitted and secure.
- CRITICAL FASTENERS SECURE



Fit all safety guards before operating. Operation is not permitted without safety guards fitted. These are not fitted at the factory due to freight limitations.

SAFE

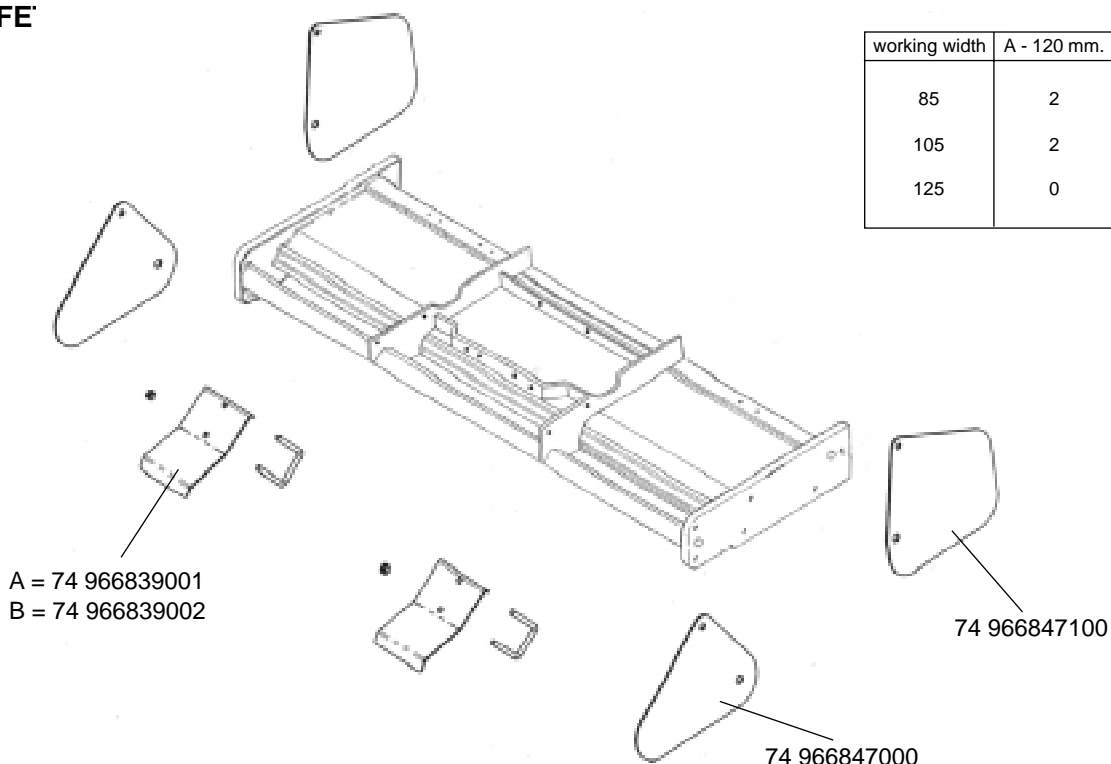

NEVER

- Touch any moving parts of the Rotavator or parts which may be hot from operation.
Check oil levels whilst the Rotavator is running.
- Carry out adjustments or repairs to a mounted Rotavator unless the tractor engine is stopped and the Rotavator firmly supported or lowered to the ground.
- Leave the tractor seat unless the Rotavator is lowered, the pto drive disengaged, the gear shift in neutral, the brake applied, the engine stopped and the ignition key removed

BE A SAFE OPERATOR BY THINKING – BEFORE ACTING

PTO DRIVE SHAFT GUARDS

HOWARD PRODUCTS are supplied with non-rotating PTO Drive Shaft which must be correctly fitted and well maintained.

Before and after each use PTO driven implements should be examined to ensure the Drive Shaft rotates freely in the guards, the guards are undamaged, securely fitted, correctly seated on the shaft grooves and the restraining chains attached to the tractor and implement.

Should the guards be broken, damaged or badly fitted the implement must not be used damaged parts have been replaced and/or bad fitting corrected.

Always ensure the guard tubes do not separate at the PTO Drive Shaft's longest working or transport length, or at its shortest.

Avoid damage to guards when the PTO Drive Shaft is being connected or disconnected from the tractor by resting it on a support.

Never allow PTO Drive Shaft Guards to fall into the implement or drop to the ground: damage will almost certainly occur.

Always ensure the sliding surfaces of the guard tubes are clean and the guard bearings lubricated.

When replacing worn or damaged sections of the Guard, use special tools available from the makers.

Always follow the fitting, lubrication and maintenance instructions supplied by the makers of the PTO Drive Shaft Guard.



**UNLESS CORRECTLY GUARDED
PTO DRIVE SHAFTS CAN KILL**

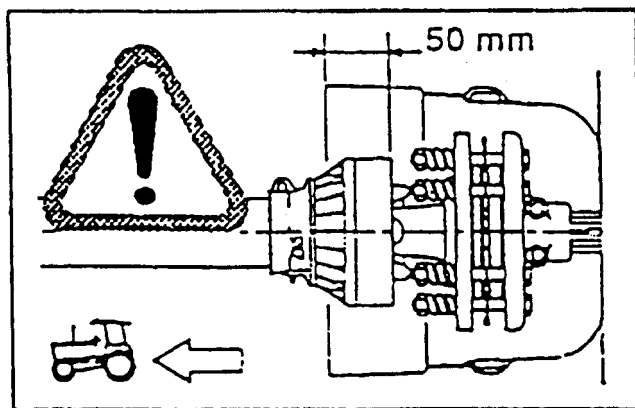

Minimum overlap in straight position

Rotavator 200

ROTAVATOR 200.

Model	Working width cm	Transport width cm	Speed rotor rpm	Weight kg	Number of blades	Tractor engine HP
R200B-085	85	102	230	132	16	12-20
R200B-105	105	122		145	20	14-20
R200B-125	125	142		160	24	16-25

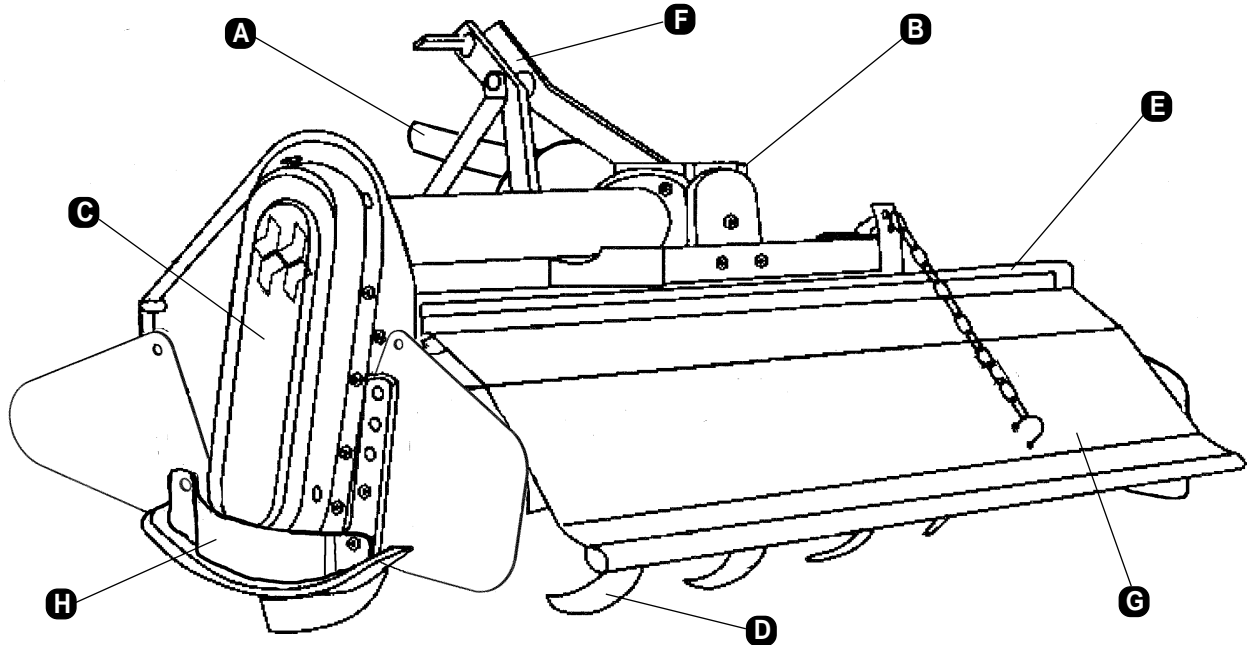

DESCRIPTION

Fig. 1 indicates assemblies referred to in the text of this manual which are named below:

- | | |
|--------------------|------------------------|
| A: PTO drive shaft | E: Frame |
| B: Gerabox | F: Top mast |
| C: Side drive | G: Trailing board |
| D: Rotor | H: Depth control skids |

R200 are designed for 12 to 25 HP tractors with cat I and II linkage. The drive is by a PTO shaft from a 540 tpm. The gearbox is single. The jackshaft transmit the power from the gearbox via the side chain or via the side gear train. An overload clutch provides protection for the transmission.

The normal tillage depth of 5 to 18 cm is regulated by the depth control skids. Rotavator are suitable for primary and secondary tillage, weed control and incorporating of material into most soil types..

NEW MACHINE

PTO shaft

For transport purposes, the PTO shaft is dismantled and must be refitted.

Lubrication and general

With the machine standing level ensure the following preparatory work has been done:

1. The gearcase filled to the level plug (A) (fig. 2) Capacity: 1 l. Use SAE 90 oil.
2. The gearbox filled up to the level mark in the inside rod (A) (fig. 3). Capacity 1 l.
3. All oil and grease points as indicated on p. 19 (Lubrication)
4. All nuts and bolts tightened. (Re-tighten after first hour's work)

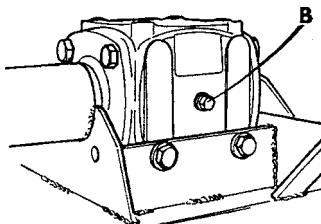

Fig. 2

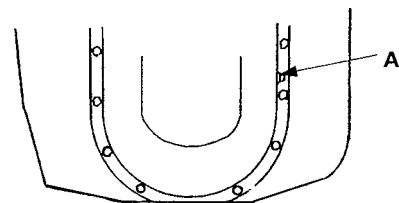

Fig. 3



SERIOUS DAMAGE CAN RESULT FROM FAILURE TO CARRY OUT THE ABOVE PROCEDURES

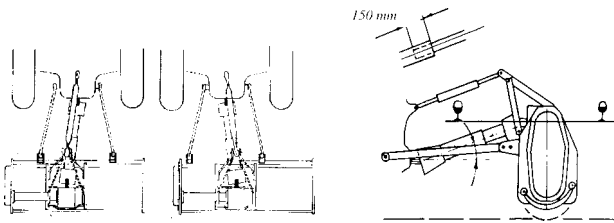

Fig. 4

Fig. 5

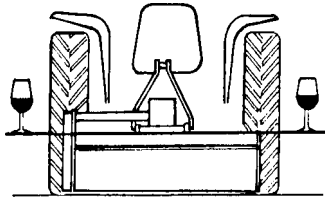

Fig. 6

ATTACHING THE ROTAVATOR TO THE TRACTOR

All models have dual mounting position, i.e. central or offset to the right. Offset mounting is achieved by repositioning the lower link mounting brackets. (fig.4)

The PTO drive shaft must be set to a safe working length to ensure the male shaft does not "bottom" or separate from the female tube under all conditions of use and transport.

To determine the correct mounting position: with the Rotavator on a firm level surface the Depth Control equipment should be adjusted until the gearbox input shaft is horizontal (fig.5). Position the tractor at a distance from the Rotavator to give 150 mm (6") minimum engagement of the male half of the PTO drive shaft in the female tube when connected to the tractor. This establishes the safe working length of PTO drive shaft for connection to the tractor.

Position the tractor lower link ball joints in line with the mounting pins. Connect the tractor lower links. Fit the tractor upper link and secure. Attach the PTO drive shaft to the pressure plate by the studs and tighten the nuts. Attach the PTO drive shaft guard chains to the tractor and Rotavator.

Attach stabilizer bar or check chains to limit sway to 50 mm (2"). Adjust tractor linkage to level Rotavator laterally and longitudinally (fig. 5 and 6). Before engaging the tractor PTO, lift the Rotavator on the hydraulic lift linkage until the PTO drive shaft attains an angle of 40 ° and set the limit stop on the hydraulic lift control quadrant. (fig. 5)



ATTENTION! : THE PTO DRIVE SHAFT ANGLE MUST NEVER EXCEED 40°.

Finally check that during transport and use the PTO drive shaft does not "bottom" or separate and that the maximum angle of 40 ° is not exceeded. Should it not be possible to obtain the aforementioned setting with your tractor, SEEK ADVICE, it may be necessary to reduce the length of the PTO drive shaft by cutting.

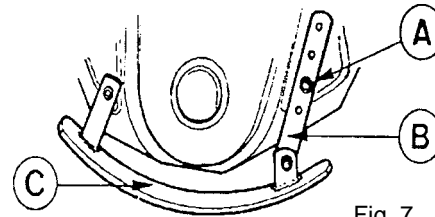

Fig. 7

Depth control

Fig. 7 illustrates how to adjust the depth control skids.

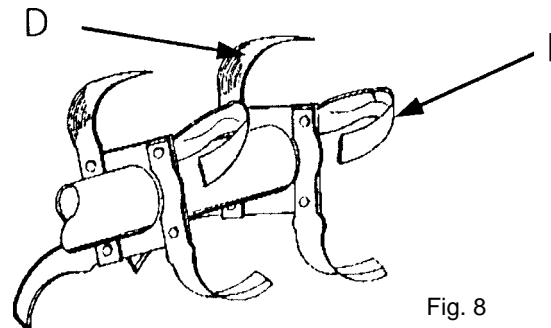

Fig. 8

ROTOR AND BLADES

R200 Rotavators are fitted with original HOWARD BLADES model 9941/42. See fig. 8 where the left blade is marked with X. Use always only ORIGINAL HOWARD BLADES and HOWARD.blade bolts.

The blades must form a «scroll» patern (fig. 9). This ensure that they enter the soil at regular intervals to even out the load on the transmission.

When replacing worn blades, remove one blade and fit the new one in its place before proceeding to the next. This will ensure that the blade «scroll» patern is maintained.

LUBRICATION + MAINTENANCE

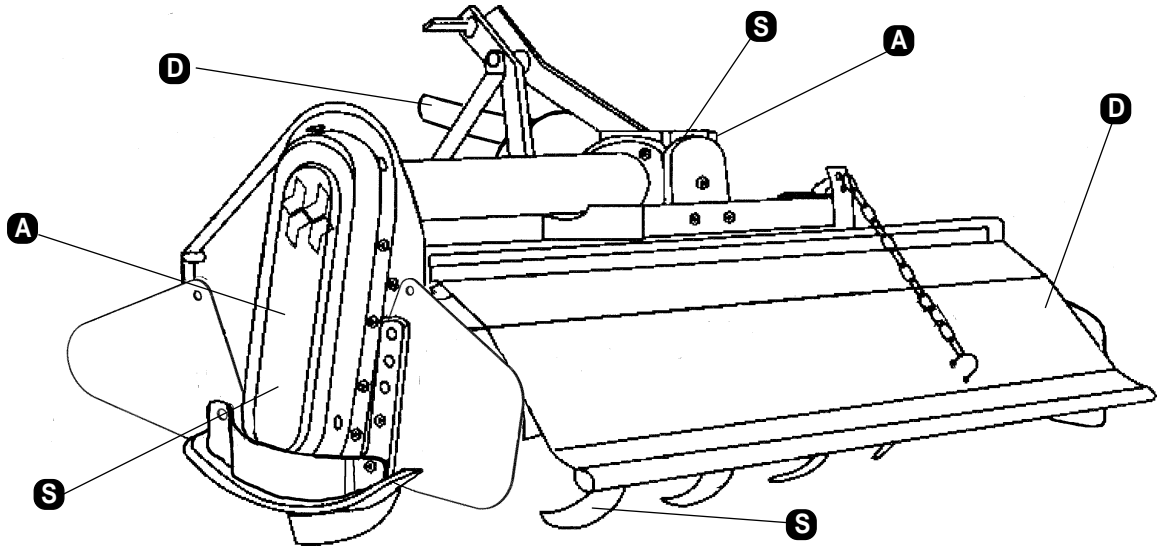

ATTENTION! IN ORDER TO OBTAIN A CORRECT MAINTENANCE AND FUNCTION OF YOUR MACHINE IS IMPERATIVE TO FOLLOW THE ENCLOSED INSTRUCTIONS:

• **(D) DAILY:**

1. Lubricate with grease gun PTO spiders.
2. Lubricate with grease gun right hand stub axle bearing

• **(S) WEEKLY:**

1. Top up with oil SAE 90 The gearbox.
2. Top up with oil SAE 90 The side drive gearcase.
3. Tighten fasteners.

• **(A) EVERY 500 WORKING HOURS:**

1. Drain flush and fill with oil SAE 90 the gearbox.
Drain flush and fill with oil SAE 90 the side drive gearcase.

Intermediate grades of tilth from coarse to fine can be obtained by:

- Adjusting the pressure on the trailing board which by impact shatters the blade cut «clods».
- Raised the trailing board also deposit weeds and trash on the surface to wither .
- With the trailing board completely pressured trash is buried and have a levelling effect on the soil.
- Increasing or decreasing the tractor speed it will also affect to the tilth.
- High working speeds may also be used for shalow work on previously borken ground.

OPERATING INSTRUCTIONS

Operational information

By simple adjustments, R200 Rotavators, will produce a range of tilths in most soil types to prepare the desired seedbed suitable to seed-drill requirements. As a general principle fine tilths are produced by a combination of slow tractor speeds and a lowered trailing board (fig.10). Conversely coarse tilths are produced by fast tractor speeds and a raised trailing board (fig.11).

Working instructions

Set the depth control skids to the required tillage depth (page 18). Select a trial trailing board and to give the type of thilth required. Engage the tractor Pto and Drive forward progressively lowering the Rotavator into the ground. Proceed for a short distance and check whether the resultant tilth is satisfactory and the tillage depth is uniform across the rotor width. If not make the apropiate adjustments to procedure the required tilth.

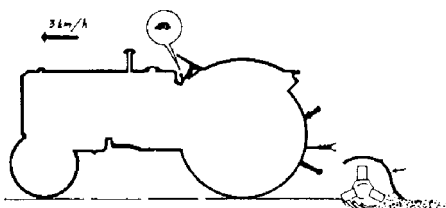

Fig. 10

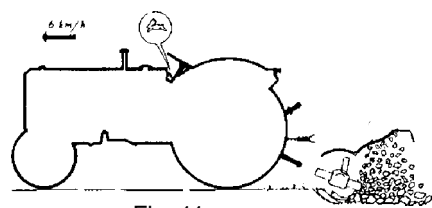

Fig. 11

Operational advice

Insufficient Depth Obtained

- (a) adjust depth control equipment
- (b) insufficient power : use lower tractor gear, reduce rotor speed
- (c) chaincase on hard soil. Further passes required
- (d) blades "trowelling" (rolling over ground), increase rotor speed or use lower tractor gear
- (e) blades incorrectly mounted

Tilth too fine

- (a) raise trailing boards
- (b) use a faster tractor gear

Tilth too coarse

- (a) lower trailing boards
- (b) use lower tractor gear
- (d) wait until soil is drier if sticks

Blades "Ballin' up" with soil

- (a) ground too sticky for working
- (b) raise trailing boards
- (d) decrease tractor speed

Excessive Blade Wear

- (a) replace loose or bent blades

Rotavator "Bumping" on Ground

- (a) obstacles entangled in blades
- (b) blades incorrectly mounted with no scroll effect or blades fitted with blunt edge leading or broken blades

Obvious Points

- (a) ROTAVATOR not level - cutting too deep on right side. Shorten right hand tractor lift rod or adjust depth control wheel
- (b) Not overlapping - drive closer to last run
- (c) Working on hillsides. Work up the slope if possible. If lateral work cannot be avoided, work from the top to the bottom in order to limit any terracing effect.

Rotavating

1. When operating the Rotavator the most suitable practice is to work in "lands"
2. The ROTAVATED ground should always be to the right of the driver.
3. ROTAVATING the field headlands should not be carried out until the "lands" have been completed.
4. Always raise the Rotavator before turning.



THE ROTAVATOR SHOULD NEVER BE LOWERED WHILST THE TRACTOR IS TURNING.